



3 Years Warranty



Biometrics



RFID



Barcode



QR Code

EXPLL-RX Grammio 200

The tripod that adapts to small installation spaces.

ExPLL-RX Grammio 200, silent and compact bi-directional tripod . The upper part is covered with high quality black tempered glass. Guarantees an average of 15 million steps without impact on the brushless mechanics.

With emergency opening, automatic reset function, LED indicators, alarm and anti-intrusion function. Integrated lights on the doors to mark valid or invalid access. Color, logo and dimensions can be customized.

3 years warranty. Ideal for hotels, gyms, buildings, shopping malls, supermarkets, reception areas, etc.

EXPII-RX Grammio 200 Tripod

The tripod that adapts to small installation spaces.

Features

- It is ideal for both indoor and outdoor use IP65.
- In case of emergency, the tripod arms lower automatically to allow free passage.
- The whole system operates with low noise and no mechanical impact.
- Automatic reset function: the turnstile arm will automatically lock within 5 seconds.
- It has standard relay signal, which can integrate with any kind of third party access control system.



Technical Specifications

Certifications	Compliance CE, ROHS, FCC
Comunication	Dry contact, Relay signal, RS485
Framework Material	304 Brushed Stainless Steel / High end black tempered Im glass
Arm Material	304 Stainless Steel
Dimensions	332 * 324 * 1000mm
Net Weight	40kg/pcs
Passage Width	550mm
Passing Direction	Single directional and Bi-directional
MCBF	15 million
Power Supply	AC220V/110V, 50/60Hz
Operation Voltage	24V DC
Power Consumption	40W
Operation Temperature	-20 °C - 75 °C
Operation Humidity	0 ~ 95% (no freeze)
Working Environment	Indoor / Outdoor
Flow rate	35 people per minute
LED Indicator	Two LED indicators on top, front and black
Emergency	Arms will drop down automatically
Flexibility	Integrate with any access control

Dimensions (mm)

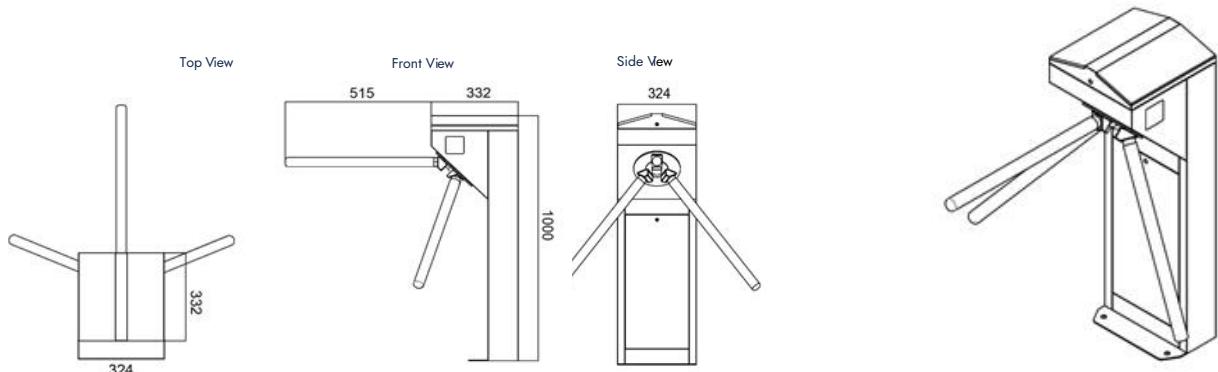

Product specifications are subject to change without notice.